

TÖYÖTÖMI

LASER CLEAN INSTRUCTION MANUAL

MODEL

LC-44

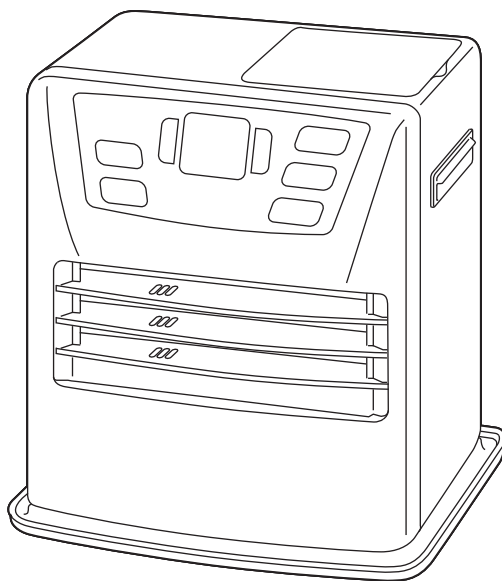

IMPORTANT

READ AND UNDERSTAND INSTRUCTIONS BEFORE USING HEATER.
RETAIN INSTRUCTIONS FOR FUTURE REFERENCE.

CONTENTS

SPECIFICATIONS	1	ROUTINE MAINTENANCE	12
PART NAME.....	1	TROUBLESHOOTING	13
OPERATION.....	5	LONG TERM STORAGE	14
EMERGENCY MESSAGE	11		

SPECIFICATIONS

MODEL	LC-44	
HEAT RATING	High	14,300 BTU / 4.2 kW
	Low	3,800 BTU / 1.1 kW
FUEL TANK CAPACITY	7.6 lit.	
BURNING TIME	19.0~ 69.0 hrs.	
DIMENSIONS (W × D × H)	435 × 315 × 437 mm	
WEIGHT	11.5 kg	
VOLTAGE / FREQUENCY	230V AC, 50 Hz	
ELECTRICAL CONSUMPTION	Igniter : 320 W	
	Continuous : 25 W	

* Matching Room Size to HEAT RATING

- Because the "Heat Load" of an area to be heated is influenced by so many factors, it is impossible to specify a heater output to an exact room size.
- If you use a heater too large for the area to be heated, the temperature you desire will be reached quickly. In such cases, to avoid overheating the area, the heater must be turned off frequently, or doors opened to other areas of the house, or windows to the outside opened to cool the area.
- If you use a heater too small for the area to be heated, it will take much longer to reach the desired temperature, in fact it may not be reached at all depending on the outside weather conditions.

PART NAME





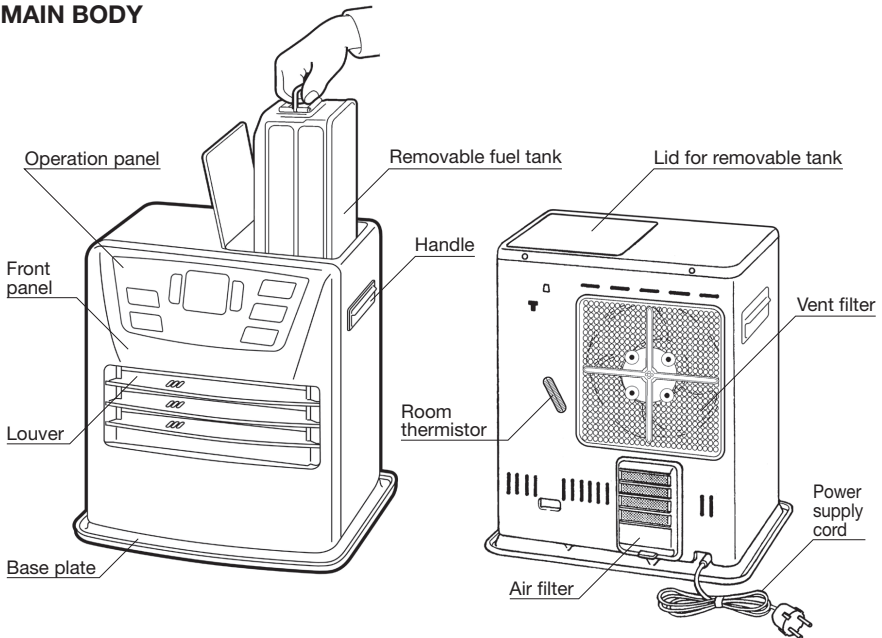

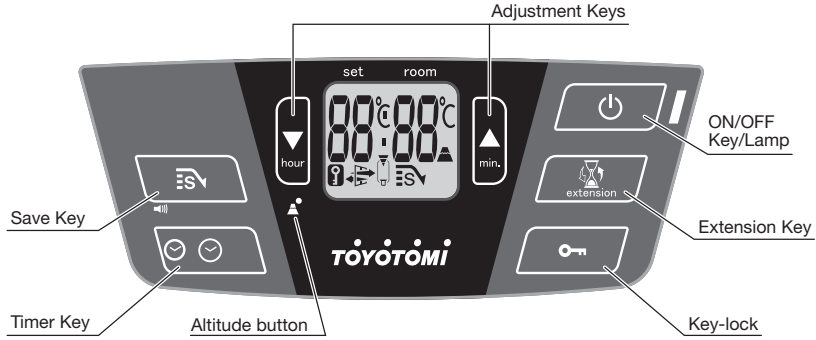

BEFORE USING HEATER, FAMILIARIZE YOURSELF WITH THE FOLLOWING OPERATING CONTROLS AND PART NAMES.

MAIN BODY



OPERATION PANEL



- | | |
|---|---|
|  ON/OFF Lamp | — flashing: Preheating mode |
| | — constant: Heater in operation |
|  key-lock Indicator | — constant: Childproof Lock is on. |
|  Temperature Indicator | — constant: The Digital Indicator shows Set temperature and Room temperature. |
|  Clock Indicator | — constant: The Digital Indicator shows current time. |
|  Timer Lamp | — constant: Heater in operation in timer mode. |
|  Save Indicator | — constant: The operation is in Save mode operation. |
|  Ventilation Indicator | — flashing: Oxygen level in room is insufficient. Heater shuts off automatically. |
|  Fuel Indicator | — constant: Fuel tank empty. Only 10 minutes burning time remaining. Digital indicator shows the remaining burning time in minutes. You can hear the alarm every 2 minutes. |
| | — flashing: Heater extinguished due to lack of fuel. (10 seconds alarm) |
|  Altitude Indicator | — constant: Altitude mode is on. |

UNPACKING AND PLACEMENT

1. Take out heater from box carefully to avoid damage.
2. Remove all packing materials from heater.
3. Make sure all screws are tight and all parts intact.

NOTE: Save shipping carton and all packing materials for future storage of your heater.

4. When positioning your heater for use, keep it away from walls and all other materials as illustrated below.

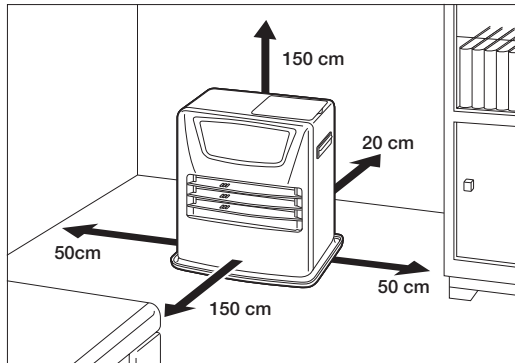

5. The floor should be firm and completely level. Reposition the heater, when it is not level.

NOTE: If your heater is not on a level surface, change its location. Do not attempt to prop heater up with books or other objects.

FUELING



WARNING : Use only water-clear kerosene (paraffin).
Never use gasoline or other flammable liquids.
ALWAYS extinguish heater before refill heater fuel tank.
Fuel heater outside the living area.

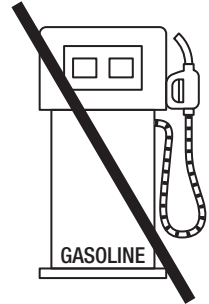

1. Open the fuel tank lid on the top of heater cabinet and lift out the removable fuel tank. Turn the removable tank upside down and remove the fuel tank cap.
2. Insert the straight tube of the manual siphon into the jerrycan; insert the siphon's flexible hose into the removable fuel tank opening.
3. Turn the air vent knob on the top of the siphon clockwise to close the vent. Start the flow of kerosene (paraffin) by squeezing the bulb of the siphon vigorously six or seven times. Once flow begins, it is no longer necessary to squeeze the bulb.
4. Check the removable tank fuel gauge while filling the tank. Stop filling by loosening the switch button on top of the pump (turn anti-clockwise), once the gauge indicates that the tank is full. Never overfill the tank, especially not when the fuel is very cold (fuel expands when it heats up).

NOTE: Be careful to avoid overfilling the tank, especially with very cold kerosene (paraffin). Overflow might occur due to expansion when the fuel warms up.

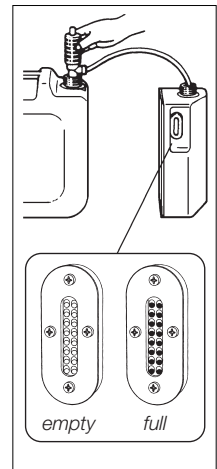

5. Remove the siphon carefully, allowing excess kerosene (paraffin) to drain from the tube back into the jerrycan. Replace fuel tank cap and tighten it securely. Be sure to wipe away any spilled kerosene (paraffin) from tank and other heater parts.
6. After making sure fuel tank cap is tightly fastened, invert tank and replace into heater body.

OPERATION

CAUTION : Always make sure that there is sufficient ventilation.

SET CLOCK

It is only possible to set the correct time, when the heater is connected to the mains and not burning.

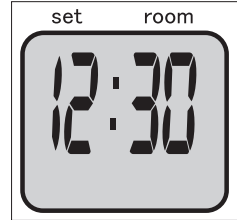

1. Use the Adjustment Keys (▼hour/▲min.) to set the time.

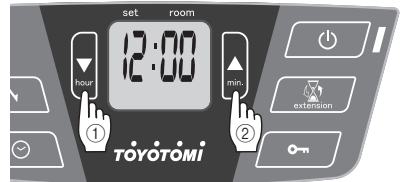

2. To set the time, press “hour” and “min.” set buttons. Individual motions will increase the time by one unit; holding continuously will raise either the “hour” or “min.” rapidly. After approximately 10 seconds the blinking will stop and the setting will be locked. 5 Minutes after switching off the heater, the information on the display will disappear and the heater will automatically switch into the stand-by position.



IGNITION

1. Just press the  key to ignite the heater. The  key will start blinking, indicating that the ignition procedure has started. This will take a short while.

2. After this time heater will automatically ignite and Operation Lamp will cease its flashing. The Operation Lamp will remain alight so long as heater is burning.

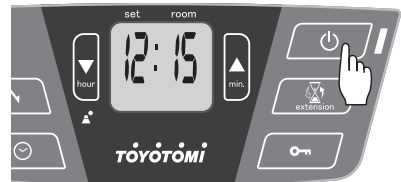



NOTE: If using your heater for the first time, or after long term storage, ignition may not take place on the first try. Press the  key again.

NOTE: Fuel pump may produce an audible operating noise at ignition. This is only temporary.

TIMER IGNITION

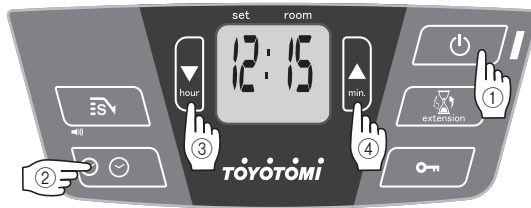
Your heater can be arranged to ignite automatically at a chosen time by use of a pre-set "Timer". This "Timer" can only be set after the clock setting has been completed.



1. Press the  key and then the "Timer" key immediately after that. The Timer Lamp will start blinking.
2. To set the "Timer" to the chosen ignition time, you should follow the same procedure as given earlier for "Clock" time setting. After approximately 10 seconds, the digital indicator will return to "Clock" mode, displaying the present time.
3. Your heater will now automatically start up the pre-set time.



4. If you wish to start up the heater at the pre-set time again, repeat the same procedure 1. mentioned above.

NOTE: The pre-set time will remain so long as the heater receives electrical power. In the event of power failure or disconnection of heater for more than 10 minutes, timer setting will be cancelled.

NOTE: If normal ignition was used to set the heater burning (i.e. the heater is burning but the Timer Lamp on the Indicator panel is out), pressing the Timer key will extinguish the heater, and the heater will be put into the "Timer" mode.

TEMPERATURE REGULATION

1. Use the Adjustment keys (▼hour/▲min.) to adjust the temperature.
2. Adjust the temperature using the key on the right (▲min.) to set the temperature to a higher setting and the key on the left (▼hour) to lower the temperature.
3. Until the room temperature has reached the set temperature, the heater will burn at either high or medium burning mode. When the room temperature reaches or slightly exceeds the set temperature, the heater will automatically shift to maintain the desired temperature.

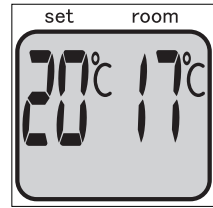

NOTE: The standard setting of the heater is 20°C. However, once the set temperature has been changed the new setting will remain in effect unless changed.

NOTE: Room temperature measurements are taken directly behind the heater. These measurements may not represent the true room temperature.

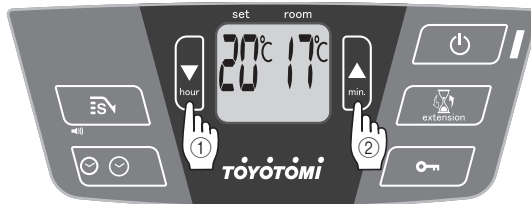

SAVE OPERATION

The "SAVE" function allows you to limit the temperature. When this function is activated, the heater will automatically switch off, when the room temperature exceeds the set temperature by 3°C. Subsequently, when the room temperature has dropped again to the set temperature, the heater will automatically switch on again. Activate the "SAVE" setting by pressing the Save key. The Save indicator will light up. Switch off the function by pressing the Save key once again.

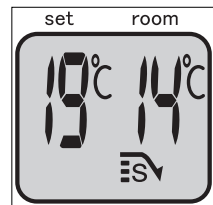

NOTE: Without the "SAVE" setting your heater will maintain the set temperature by approximation as well, by adjusting its heating capacity. "SAVE" is an economy setting, which you can use when, for instance, you are not present in the room or to keep it frost-free.

CHILDPROOF LOCK

The childproof lock can be used to prevent children accidentally changing the heater settings. When the heater is burning and the childproof lock is on, the heater can only be switched off. Other functions are blocked then. If the heater has already been switched off, the childproof lock also prevents accidental ignition of the heater.



Activate the childproof lock by pressing the Key-lock key and holding it down for more 3 seconds. The Key-lock indicator will light up indicating that the childproof lock has been activated. Switch off the childproof lock by pressing the Key-lock key and holding it down for more than 3 seconds once again.

VENTILATION INDICATOR

When the VENT indicator indicator starts blinking, this is a sign that the room is not vented sufficiently. If you do not provide additional ventilation, the heater will switch off automatically after some time. If the indicator indicator continues blinking after extra ventilation, please contact your dealer.

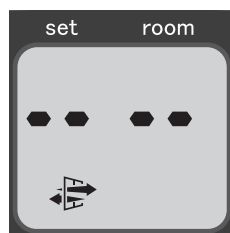

FUEL INDICATOR

When the Fuel Indicator lights up, it means that there is only fuel left for 10 more minutes. The count-down of the remaining heating time can be seen in the Digital indicator. Now you have two options:

- ▶ you remove the removable fuel tank and refill it outside the living room or
- ▶ you push the Extension key. By pushing this button, the remaining heating time will extend to 90 minutes. The heater will automatically switch back to its lowest position. In the display the number 90 will appear, which will decline to 10. At the arrival of 10, you will hear an alarm signal every two minutes, warning you to refill the removable tank. If you do not react, the heater will extinguish by itself. The heater will also sound a warning signal, when it switches off. The Fuel Indicator will blink, while four lines (---) are blinking in the Digital indicator. You can stop this by pressing the  key once more.

Once the heater has used up all its fuel and extinguished, it will take some time, after the refill, before the heater is completely ready for use again.

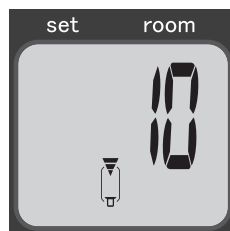

AUTOMATIC CLEANING MODE

When the heater has been burning continuously for two hours at its highest setting, the burner will automatically start an autoclean procedure. The display will show the autocleaning code CL:01 running back to CL:05 . The procedure takes 5 minutes, during which the heater will burn at its lowest setting, while the burner autocleans. When the burner is clean again, the heater will automatically switch back to the highest setting again.

TURNING OFF HEATER

While heater is burning, press power switch to "OFF" position. This will extinguish heater and ON/OFF Lamp on the indicator panel will go out. The circulation fan motor will operate further, for approximately 90 seconds to assist in cooling down heater.



NEVER: Turn heater off by disconnecting the heater plug from the main electrical supply.

DO NOT: Restart your heater for at least ten minutes.

AUTOMATIC DEACTIVATION

This heater is fitted with a safety system that ensures that it switches off automatically after 69 hours continuous operation. The following will then appear in the display: $69 Hr$. If desired, you can switch the heater on again by pressing the ⏻ key.



SET ALTITUDE

1. If the heater is used at a height of 800 m to 1300 m, use the altitude mode 1. Push the altitude button with thin rod like a clip and plug into the outlet simultaneously. Then “1 ▲” will be shown on the display.



2. If the heater is used at a height of 1300 m to 1900 m, use the altitude mode 2. After setting the altitude mode 1, push the altitude button with thin rod and plug into the outlet simultaneously again. Then “2 ▲” will be shown on the display.



3. Switch off the altitude mode by pressing the altitude button and into the outlet simultaneously after setting altitude mode 2. Then “0” will be shown on the display and “▲” will be disappeared.



NOTE: When the altitude mode 1 is set, the altitude mark “▲” is lit on the display.

When the altitude mode 2 is set, the altitude mark “▲” is blinking during operation.

NOTE: In the event of power failure or disconnection of heater, the altitude setting will remain.

! Do not use the heater at a height of over 1900 meters.

SWITCH THE VOLUME

This heater can be switched the buzzer sound volume. The initial setting is in High level.

1. Push the SAVE key and holding it down for more than 3 seconds, then the buzzer sound volume is switched from High to Low.
2. Push the SAVE key and holding it down for more than 3 seconds again, then the buzzer sound volume is switched from Low to High.

NOTE: The volume level is Low and High only, but the alarm by safety device sounds in High level.

NOTE: When the heater has been unplugged or after a power failure, the volume will be the initial setting High.

EMERGENCY MESSAGE

In the event that heater should extinguish itself, without any action or your part, you should look to the digital indicator for any of the following messages.

MESSAGE (Digital Indicator)	MESSAGE MEANING
E-0	Temperature within the heater too high.
F-0	Power interrupted. You can re-ignite the heater.
E-1	Thermostat is broken or disconnected. Contact your dealer.
F-1	Faulty burner thermistor. Contact your dealer.
E-2	Primary flame rod is malfunctioning and /or dirty.
E-23	Re-ignite the heater immediately after extinguishing. Wait for approx. 30 sec. and re-ignite after inserting the plug again.
E-5	You have accidentally activated your safety tip-over switch. You should reset this device as described, press the "OFF" button and restart your heater.
E-6	Burner flame has been extinguished during operation. Check to see if air filter is clogged with dust. If so, clean air filter.
E-7	Room temperature above 32°C
E-8	Failure of blower motor.
E-81	Abnormal frequency. Insert the plug into the wall-socket again. Contact your dealer.
E-9	Air filter dirty; or Fuel pump dirty.
69 H-	The heater has been in operation continuously for a period of 69 hours and has turned itself off automatically. Switch the heater back on.
--:-- (& blinking FUEL-Indicator)	Out of fuel. Refill removable fuel tank.
--:-- (& blinking VENT-Indicator)	Too little ventilation. Ventilate better.

ROUTINE MAINTENANCE

CAUTION: Be sure to unplug heater before performing any checks or cleaning.

CAUTION: Do not remove any parts from the heater except removable fuel tank, fuel acceptance fitting and air filter.

WARNING: Allow heater to cool completely before cleaning or maintenance.

1. Clean Air Filter

Clean the air filter with a vacuum cleaner on a weekly basis. If filter is clogged with dust or lint, smoking and improper combustion may result.

NOTE: If filter was washed in water, dry thoroughly before replacing.

NOTE: Never wipe with cloth, it will clog filters further.

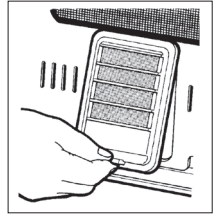

2. Clean Fan Cover

Using a vacuum cleaner, remove any dust from the fan cover at the back of the heater.

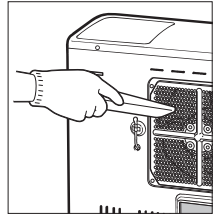

3. Clean Fuel Acceptance Fitting

When dirt or dust accumulates in the fuel acceptance fitting, it should be cleaned. Check fuel acceptance fitting each time your refuel.

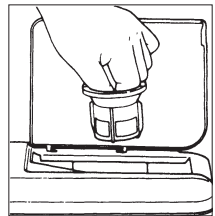

4. Check for fuel leaks

Make it a habit to check for signs of fuel leakage. Wipe off any spilled fuel on the sub tank and removable fuel tank. Spilled fuel may cause odor or risk of fire.

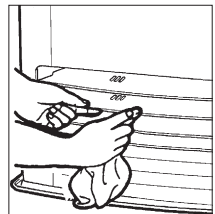

5. Clean Louvers

Dust and stains should be wiped off louvers with a damp cloth. If dust and stains are allowed to build up over a period of time, removal will become difficult. Make it a point to wipe clean regularly.

TROUBLESHOOTING

Should problems arise during operation or ignition, use this chart to determine the cause and the proper steps to take. Be sure to unplug heater and allow to cool completely before taking corrective measures.

PROBLEM	CAUSE	SOLUTION
POWER LAMP FAILS TO TURN ON	<ul style="list-style-type: none"> –Disconnected power plug –Incorrect wiring –Circuit board malfunction 	<ul style="list-style-type: none"> –Plug into 230V AC outlet. –Consult your dealer. –Consult your dealer.
NO IGNITION	<ul style="list-style-type: none"> –Out of fuel –Clogged air filter –Use of inferior kerosene (paraffin) –Incorrect wiring –Circuit board, ignition heater or fuel pump malfunction 	<ul style="list-style-type: none"> –Refuel –Clean air filter. –Remove fuel and refuel using fresh, clear kerosene (paraffin). –Consult your dealer. –Consult your dealer.
ODOR	<ul style="list-style-type: none"> –Clogged air filter –Spilled kerosene (paraffin) –Use of inferior kerosene (paraffin) 	<ul style="list-style-type: none"> –Clean air filter –Wipe off any kerosene (paraffin) spills from fuel sub tank, removable fuel tank and drip tray. –Remove fuel and refuel using fresh, water-clear kerosene (paraffin).
EXTINGUISHED AFTER IGNITION	<ul style="list-style-type: none"> –Excessive room temperature –Oxygen shortage in room –Tip-over switch activated –Water in fuel acceptance fitting –Out of fuel –Flame sensor or fuel pump malfunction –High limit switch activated 	<ul style="list-style-type: none"> –Allow room to cool. –Open doors and windows to ventilate room thoroughly. –Reignite. –Remove fuel and refuel using fresh, water-clear kerosene (paraffin). –Refuel –Consult your dealer. –Clean circulation fan cover, remove any obstructions.
POOR COMBUSTION/ NOISY COMBUSTION	<ul style="list-style-type: none"> –Clogged air filter –Loose screws or incorrect assembly –Incorrect wiring –Circuit board or fuel pump malfunction –Altitude too high 	<ul style="list-style-type: none"> –Clean air filter. –Consult your dealer. –Consult your dealer. –Consult your dealer. –Consult your dealer.

If the corrective measures outlined above do not solve the problem, please consult your dealer.

LONG TERM STORAGE

At the end of the heating season, you must store the heater in a dust-free place, if possible in its original packaging. The following procedures are recommended.

1. Drain Fuel Tank

Remove any kerosene (paraffin), dust or water remaining in the fuel sub tank and removable fuel tank to prevent rusting.

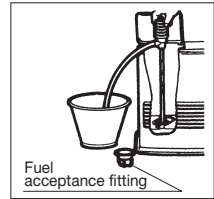

2. Clean Heater

Wipe off any dirt or dust on heater with a damp cloth, then wipe again using a dry cloth.



3. If your heater needs any service or repair, now is the time to call your dealer to have it done before storage. That way, it will be ready for immediate use when the next heating season begins.

4. Store Heater

The original shipping carton is the best place to store your heater. If you do not have the original packing materials, cover heater with a large plastic bag and store in a dry place.



